

HAZARDOUS LOCATION VALVES



Note: This valve also available as an operator. Refer to following page.

Series 50 EW >> Model EW54

Encapsulated Hazardous Location – 3-Way Normally Open Valve

A UL and CSA listed, low watt, miniature hazardous location valve with minimal space and energy requirements in volatile environments. Air and other fluids, compatible with standard Buna seals. Hot water, steam, gasoline, oils, some hydraulic fluids, and many other media require special seal materials.

- **Smallest hazardous location solenoid valve.**
- **Best ambient and high temperature ratings on the market.**
- **NEMA 4 rating is standard with encapsulated coil.**

OPERATING CONDITIONS

Media: Air, and other fluids compatible with standard Buna seals. Hot water, steam, gasoline, oils, some hydraulic fluids, and many media require special seal materials. (Series 50 pressure ratings may change due to the viscosity of the liquid.)*

Valve Temperature Range: Standard Valves - 0°F (-18°C) to 140°F (60°C) ambient; 0°F (-18°C) to 150°F (65°C) media. Optional Valves - can tolerate much higher or much lower ambient and media temperatures.*

Maximum Operating Pressure Differentials: See table on proceeding page.

Burst Pressure: 5000 PSI

Leakage: Bubble tight for standard valves.

Vacuum: To 5 Microns*

ELECTRICAL CHARACTERISTICS

Coil Voltage: 16 to 547V AC 60 HZ. and 14.5 to 490V AC 50 HZ. – 6 to 200V DC

Nominal Power: AC – 5.0 Watts DC – 5.0 Watts

Coil Construction: Encapsulated Class F Coil with third wire ground

Typical Response Time on Air: 4 - 16 Milliseconds

Operating Speed: Up to 600 CPM

Duty Cycle: Continuous

MECHANICAL CHARACTERISTICS

Body: Stainless Steel (Std.)

Internal Components: Stainless Steel

Elastomers: Nitrile (Buna) (Std.). Many other elastomers available.*

Orifice Diameter: See table on proceeding page.

Porting: 1/8" NPT (Std.)

Housing: Encapsulated with 1/2 NPT conduit

Listings: Valves are UL listed for Hazardous Locations – Class I, Div 1, Groups A, B, C, and D - Class II, Div 1, Groups E, F, and G; Div 2, Groups A, B, C, D, E, F, and G. "T" Rating as low as T4.

Life Expectancy: Millions of cycles, depending on application, lubrication, etc.

Valve Weight: 0.60 lbs

Repair Packs: See table on proceeding page.

Options: Alternate Port Locations, Metering, Alternate Elastomers, All Stainless Steel Construction*

* Consult representative or factory for options and specifications.

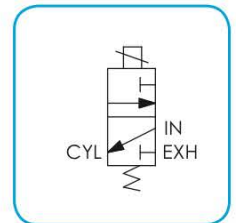
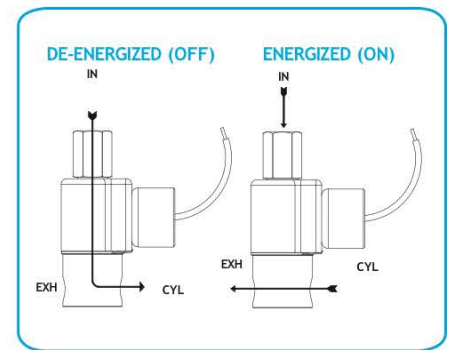

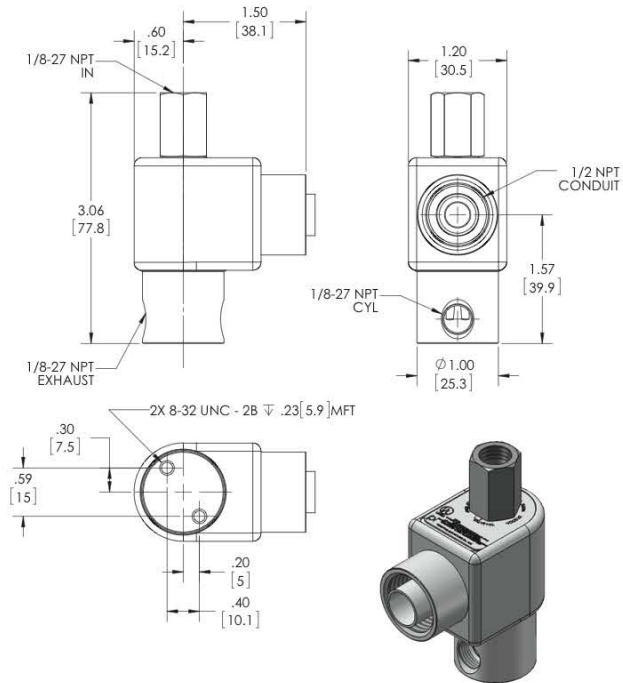

**SERIES 50 EW
MODEL EW54
3WNO
EXPLOSION PROOF**

VALVE SPECIFICATIONS

MAX. OPER. PRESS. DIFF.		ORIFICE SIZE		CV FACTOR		VALVE NUMBER
AC	DC	N.O.	N.C.	N.O.	N.C.	
200	150	1/32	1/32	.020	.022	EW54GG8XDCCP
125	90	3/64	3/64	.048	.055	EW54HH8XDCCP
100	60	1/16	1/16	.075	.075	EW54JJ8XDCCP
75	40	5/64	5/64	.134	.134	EW54VV8XDCCP
50	25	3/32	3/32	.150	.150	EW54KK8XDCCP

ORDERING INFORMATION:

WHEN ORDERING VALVES OR REPAIR PACKS ADD VOLTAGE AND FREQUENCY TO COMPLETE VALVE NUMBER. EXAMPLES: VALVE (EW54JJ8XDCCP 120/60) REPAIR PACK (KEW54JJ AC)

WHEN ORDERING OPERATORS ADD THE LETTER "O" TO THE FRONT OF THE VALVE NUMBER, REPLACE BODY PORT NUMBER WITH THE LETTER "D": EXAMPLE: OPERATOR (QEW54JJ8XDCCP 120/60)