

HAZARDOUS LOCATION VALVES



Note: This valve also available as an operator. Refer to following page.

Series 50 EW >> Model EW51

Encapsulated Hazardous Location – 2-Way Normally Open Valve

A UL and CSA listed, low watt, miniature hazardous location valve with minimal space and energy requirements in volatile environments. Air and other fluids, compatible with standard Buna seals. Hot water, steam, gasoline, oils, some hydraulic fluids, and many other media require special seal materials.

- **Smallest hazardous location solenoid valve.**
- **Best ambient and high temperature ratings on the market.**
- **NEMA 4 rating is standard with encapsulated coil.**

OPERATING CONDITIONS

Media: Air, and other fluids compatible with standard Buna seals. Hot water, steam, gasoline, oils, some hydraulic fluids, and many media require special seal materials. (Series 50 pressure ratings may change due to the viscosity of the liquid.)*

Valve Temperature Range: Standard Valves - 0°F (-18°C) to 140°F (60°C) ambient; 0°F (-18°C) to 150°F (65°C) media. Optional Valves - can tolerate much higher or much lower ambient and media temperatures.*

Maximum Operating Pressure Differentials: See table on proceeding page.

Burst Pressure: 5000 PSI

Leakage: Bubble tight for standard valves.

Vacuum: To 5 Microns*

ELECTRICAL CHARACTERISTICS

Coil Voltage: 16 to 547V AC 60 HZ. and 14.5 to 490V AC 50 HZ. – 6 to 200V DC

Nominal Power: AC – 5.0 Watts DC – 5.0 Watts

Coil Construction: Encapsulated Class F Coil with third wire ground

Typical Response Time on Air: 4 - 16 Milliseconds

Operating Speed: Up to 600 CPM

Duty Cycle: Continuous

MECHANICAL CHARACTERISTICS

Body: Stainless Steel (Std.)

Internal Components: Stainless Steel

Elastomers: Nitrile (Buna) (Std.). Many other elastomers available.*

Orifice Diameter: See table on proceeding page.

Porting: 1/8" NPT (Std.)

Housing: Encapsulated with 1/2 NPT conduit

Listings: Valves are UL listed for Hazardous Locations – Class I, Div 1, Groups A, B, C, and D - Class II, Div 1, Groups E, F, and G; Div 2, Groups A, B, C, D, E, F, and G. "T" Rating as low as T4.

Life Expectancy: Millions of cycles, depending on application, lubrication, etc.

Valve Weight: 0.60 lbs

Repair Packs: See table on proceeding page.

Options: Alternate Port Locations, Metering, Alternate Elastomers, All Stainless Steel Construction*

* Consult representative or factory for options and specifications.

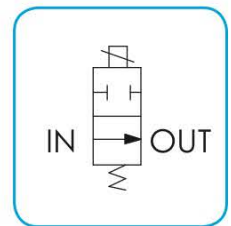
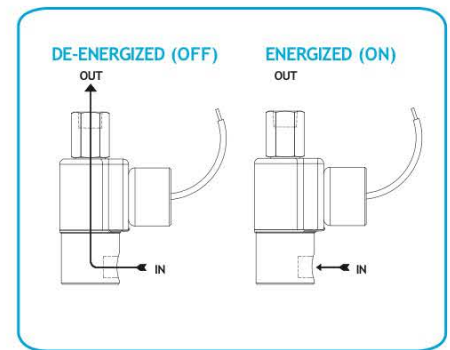

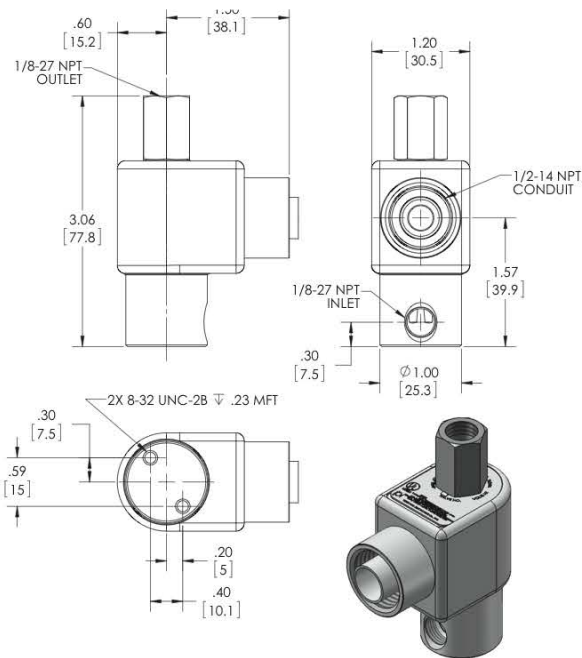

**SERIES 50 EW
MODEL EW51
2WNO
EXPLOSION PROOF**

VALVE SPECIFICATIONS

MAX. OPER. PRESS. DIFF.		ORIFICE SIZE	CV FACTOR	VALVE NUMBER
AC	DC	N.O.	N.O.	
700*	700*	1/32	.020	EW51G8XCCP
500	500	3/64	.048	EW51H8XCCP
200	200	1/16	.075	EW51J8XCCP
135	135	5/64	.134	EW51V8XCCP
100	100	3/32	.150	EW51K8XCCP

* FKM seals not recommended for pressure ratings above 500 PSI

ORDERING INFORMATION:

WHEN ORDERING VALVES OR REPAIR PACKS ADD VOLTAGE AND FREQUENCY TO COMPLETE VALVE NUMBER. EXAMPLES: VALVE (EW51J8XCCP 120/60) REPAIR PACK (KEW51J AC)

WHEN ORDERING OPERATORS ADD THE LETTER "O" TO THE FRONT OF THE VALVE NUMBER, REPLACE BODY PORT NUMBER WITH THE LETTER "D": EXAMPLE: OPERATOR (OEW51J8DCCP 120/60)