

LOW WATT VALVES



Note: This valve also available as an operator. Refer to following page.

Series 50 LW >> Model LW53

Low Wattage –3-Way Normally Closed – Piped Exhaust

General purpose for pneumatic and hydraulic applications. The versatility of these valves is increased to include the handling of hot air, hot water, refrigerants and many other media, by the use of different seals. Air and other fluids compatible with standard Buna seals. Hot water, steam, gasoline, oils, some hydraulic fluids, and many media require special seal materials.

- General purpose valve with reduced power consumption.
- Increased versatility.
- For pneumatic and hydraulic application.

OPERATING CONDITIONS

Media: Air and other fluids compatible with standard Buna seals. Hot water, steam, gasoline, oils, some hydraulic fluids, and many media require special seal materials. (Series 50 pressure ratings may change due to the viscosity of the liquid.)*

Valve Temperature Range: Standard Valves - 0°F (-18°C) to 140°F (60°C) ambient; 0°F (-18°C) to 150°F (65°C) media. Optional Valves - can tolerate much higher or much lower ambient and media temperatures.*

Maximum Operating Pressure Differentials: See table on proceeding page.

Burst Pressure: 5000 PSI

Leakage: Bubble tight for standard valves.

Vacuum: To 5 Microns*

ELECTRICAL CHARACTERISTICS

Coil Voltage: 12 to 370V AC 60 HZ. and 10.5 to 345V AC 50 HZ. – 6.0 to 120V DC

Nominal Power: AC – 2.5 Watts DC – 2.5 Watts

Coil Construction: Molded and potted Class F. (Class H optional)

Typical Response Time on Air: 4 - 16 Milliseconds

Operating Speed: Up to 600 CPM

Duty Cycle: Continuous

MECHANICAL CHARACTERISTICS

Body: Stainless Steel (Std.), Brass (Opt.) or Aluminum (Opt.)

Internal Components: Stainless Steel

Elastomers: Nitrile (Buna) (Std.). Many other elastomers available.*

Orifice Diameter: See table on proceeding page.

Porting: 1/8" NPT (Std.)

Housing: Grommet and 1/2" NPT conduit - many options available.*

Listings: Most valves are UL and CSA listed – consult factory.

Life Expectancy: Millions of cycles, depending on application, lubrication, etc.

Valve Weight: Grommet Valve: 0.38 lbs, Conduit Valve: 0.44 lbs

Repair Packs: See table on proceeding page.

Options: Alternate Port Locations, Metering and Alternate Elastomers*

* Consult representative or factory for options and specifications.

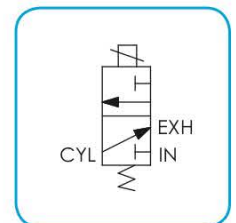
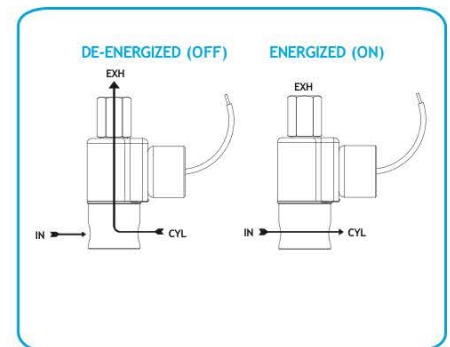

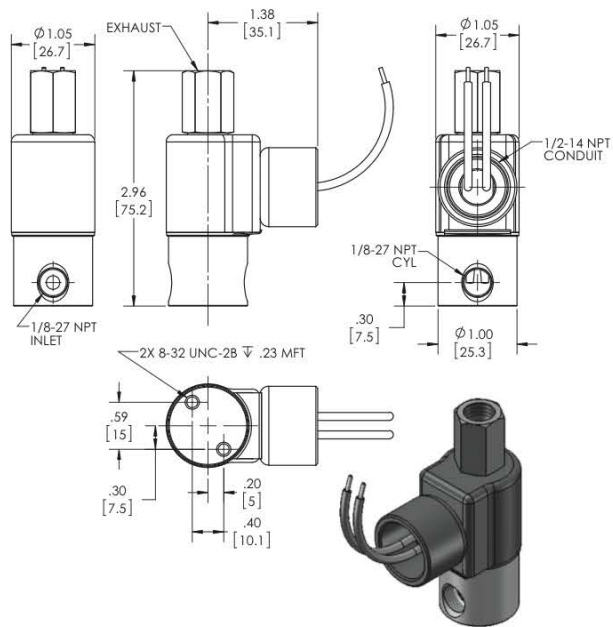

**SERIES 50 LW
MODEL LW53
3WNC PIPED EXHAUST
CONDUIT CONNECTION**

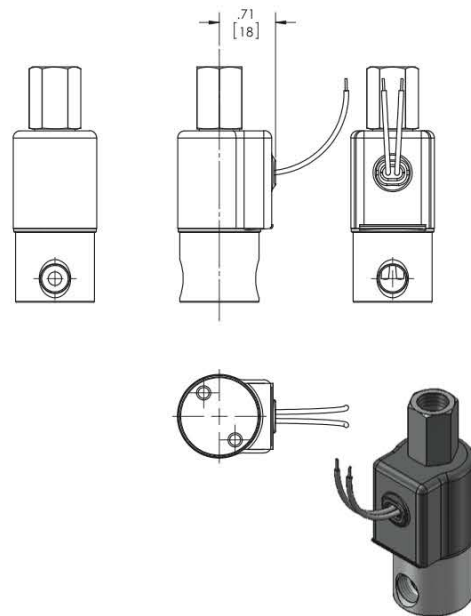

**SERIES 50 LW
MODEL LW53
3WNC PIPED EXHAUST
GROMMET HOUSING WITH LEADS**

VALVE SPECIFICATIONS

MAX. OPER. PRESS. DIFF.		LIQUID		ORIFICE SIZE		CV FACTOR		VALVE NUMBER	
GAS				N.C.		N.O.		GROMMET 1/8 NPT	CONDUIT 1/8 NPT
AC	DC	AC	DC	N.C.	N.O.	N.C.	N.O.		
215	135	215	135	1/32	1/32	.022	.022	LW53GG8XGM	LW53GG8XCM
215	120	120	65	1/32	3/64	.022	.048	LW53GH8XGM	LW53GH8XCM
135	50	40	30	1/32	1/16	.022	.075	LW53GJ8XGM	LW53GJ8XCM
70	35	30	20	1/32	5/64	.022	.134	LW53GV8XGM	LW53GV8XCM
55	30	25	15	1/32	3/32	.022	.156	LW53GK8XGM	LW53GK8XCM
120	70	120	65	3/64	3/64	.055	.048	LW53HH8XGM	LW53HH8XCM
120	50	40	30	3/64	1/16	.055	.075	LW53HJ8XGM	LW53HJ8XCM
70	35	30	20	3/64	5/64	.055	.134	LW53HV8XGM	LW53HV8XCM
55	30	25	15	3/64	3/32	.055	.156	LW53HK8XGM	LW53HK8XCM
85	40	40	30	1/16	1/16	.075	.075	LW53JJ8XGM	LW53JJ8XCM
70	35	30	20	1/16	5/64	.075	.134	LW53JV8XGM	LW53JV8XCM
55	30	25	15	1/16	3/32	.075	.156	LW53JK8XGM	LW53JK8XCM
50	30	30	20	5/64	5/64	.134	.134	LW53VV8XGM	LW53VV8XCM
50	30	25	15	5/64	3/32	.134	.156	LW53VK8XGM	LW53VK8XCM
35	20	25	15	3/32	3/32	.150	.156	LW53KK8XGM	LW53KK8XCM

ORDERING INFORMATION:

WHEN ORDERING VALVES OR REPAIR PACKS ADD VOLTAGE AND FREQUENCY TO COMPLETE VALVE NUMBER. EXAMPLES: VALVE (LW53JJ8XGML 120/60) REPAIR PACK (KLW53JJD AC)

WHEN ORDERING OPERATORS ADD THE LETTER "O" TO THE FRONT OF THE VALVE NUMBER, REPLACE BODY PORT NUMBER WITH THE LETTER "D": EXAMPLE: OPERATOR (OLW53JJ8DGML 120/60)